



# Move more loads faster, minimize damage and stay competitive.

## APPLICATIONS

Designed for any application using pallets or containers to transport product, Cascade's Single-Double Pallet Handler allows single pallet handling without protrusion outside the truck profile. Spreading the forks hydraulically allows handling of two pallets side by side. Sideshifting provides added flexibility for aligning forks or pallets in tight areas.

## FEATURES

- Superior visibility through and over the frame for damage free handling at all stacking heights
- All steel frame for increased overall durability, eliminating flexing
- Easy access cylinders for quick servicing
- Bolt-on Interchangeable forks for low service cost
- Full-length, fully enclosed wrap around UHMW plastic bearings provide maximum strength and full bearing support, greatly reducing wear on bearing surface
- Dual class II and III mountings, easily field converted
- Inner forks mounted on a chrome pin for greater inner fork stability
- Adjustable fork set spread for ability to handle different types of pallets

## OPTIONS

- Various load backrest configuration heights, fork lengths and sections
- Various fork set spreads and opening ranges
- Quick-disconnect lower hooks
- Drop shank forks—forks are lowered relative to the attachment frame
- Independent fork set control—allows moving left or right fork set independent of the opposite fork set
- Non-Sideshifting models available

*Designed with great visibility, easier maintenance, and superior durability.*



**cascade**  
corporation

# SINGLE-DOUBLE PALLET HANDLER

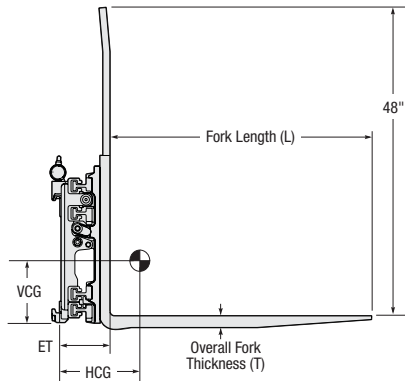

Single-Doubles can handle single pallets or, by spreading the forks, two pallets side by side.

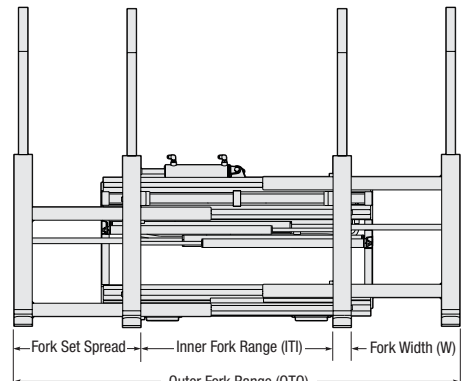
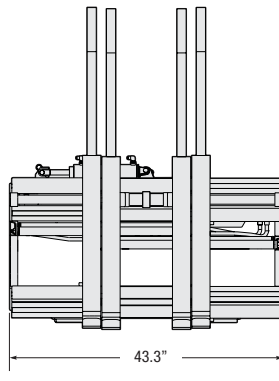

## Sideshifting

Capacity @ 24" (600mm) Load Center	Catalog Order Number	Mtg. Class	Min. Truck Carriage Width	Weight	Effective Thickness ET	Horizontal Ctr. of Gravity HCG	Vertical Ctr. of Gravity VCG	Inner Fork Range ITI	Outer Fork Range OTO	Avg. Pallet Spread	Fork Set Spread	Fork Section
												L x W x T in.
<b>36" x 36" Beverage Pallets</b>												
5,500 (2,500)	25G-FDS-A005	II	36.0	1,080	8.9	7.7	10.9	13.0 - 32.1	26.0 - 80.1	20.0	24.0	36.0 x 3.2 x 1.8
5,500 (2,500)	25G-FDS-B005	III	36.0	1,075	8.7	7.5	11.2	13.0 - 32.1	26.0 - 80.1	20.0	24.0	36.0 x 3.2 x 1.8
6,000 (2,800)	28G-FDS-B005	III	36.0	1,130	8.9	7.9	11.6	13.0 - 32.1	26.0 - 80.1	20.0	24.0	36.0 x 3.2 x 2.0
7,000 (3,200)	32G-FDS-B005	III	36.0	1,210	9.2	8.5	11.3	13.0 - 32.1	26.0 - 80.1	20.0	24.0	36.0 x 3.2 x 2.4
<b>48" x 40" Block and GMA Pallets ①</b>												
4,800 (2,200)	22G-FDS-A221	II	36.0	1,125	8.7	8.0	10.8	14.6 - 28.7	27.6 - 82.7	15.0	27.0	42.0 x 3.2 x 1.6
4,800 (2,200)	22G-FDS-B221	III	36.0	1,125	8.5	7.8	11.1	14.6 - 28.7	27.6 - 82.7	15.0	27.0	42.0 x 3.2 x 1.6
5,500 (2,500)	25G-FDS-A221	II	36.0	1,170	8.9	8.4	10.8	14.6 - 28.7	27.6 - 82.7	15.0	27.0	42.0 x 3.2 x 1.8
5,500 (2,500)	25G-FDS-B221	III	36.0	1,160	8.7	8.2	11.1	14.6 - 28.7	27.6 - 82.7	15.0	27.0	42.0 x 3.2 x 1.8
6,000 (2,800)	28G-FDS-B221	III	36.0	1,205	8.9	8.8	10.7	14.6 - 28.7	27.6 - 82.7	15.0	27.0	42.0 x 3.2 x 2.0
7,000 (3,200)	32G-FDS-B221	III	36.0	1,245	9.2	9.6	10.3	14.6 - 28.7	27.6 - 82.7	15.0	27.0	42.0 x 3.2 x 2.4
<b>48" x 40" GMA Pallets</b>												
5,500 (2,500)	25G-FDS-A009	II	36.0	1,135	8.9	8.7	10.5	18.9 - 31.0	31.9 - 87.0	19.0	28.0	42.0 x 3.2 x 1.8
5,500 (2,500)	25G-FDS-B009	III	36.0	1,125	8.7	8.5	10.7	18.9 - 31.0	31.9 - 87.0	19.0	28.0	42.0 x 3.2 x 1.8
6,000 (2,800)	28G-FDS-B009	III	36.0	1,190	8.9	9.0	11.1	18.9 - 31.0	31.9 - 87.0	19.0	28.0	42.0 x 3.2 x 2.0
7,000 (3,200)	32G-FDS-B009	III	36.0	1,275	9.2	9.7	10.7	18.9 - 31.0	31.9 - 87.0	19.0	28.0	42.0 x 3.2 x 2.4
<b>44" x 56" Container Pallets</b>												
5,500 (2,500)	25G-FDS-A013	II	36.0	1,195	8.9	11.3	9.7	13.0 - 28.1	26.0 - 80.1	11.0	26.0	54.0 x 3.2 x 1.8
5,500 (2,500)	25G-FDS-B013	III	36.0	1,185	8.7	11.2	10.0	13.0 - 28.1	26.0 - 80.1	11.0	26.0	54.0 x 3.2 x 1.8
6,000 (2,800)	28G-FDS-B013	III	36.0	1,255	8.9	11.8	10.2	13.0 - 28.1	26.0 - 80.1	11.0	26.0	54.0 x 3.2 x 2.0
7,000 (3,200)	32G-FDS-B013	III	36.0	1,360	9.2	12.7	9.8	13.0 - 28.1	26.0 - 80.1	11.0	26.0	54.0 x 3.2 x 2.4

- ▶ The outer fork tines are higher than the inner fork tines
- ▶ 8" (200mm) total sideshift
- ▶ Other fork lengths available
- ▶ Plastic pallets may require modified fork dimensions

① This model can handle GMA type stringer and block pallets, including Chep Type III and Mark 55 pallets. The single mode fork positioning range is 15" to 21" in to in, or 27.5" to 33.5" out to out. Average pallet spread is 8" for both pallets. No additional truck auxiliary valves required, beyond the normal two auxiliary valves.

## HYDRAULIC FLOW & PRESSURE

Minimum	Recommended	Maximum	Operating Pressure
4 GPM	7 GPM	7 GPM	2900 PSI

## INSTALLATION KITS

Model	Catalog Order No.
Class II	6072233
Class III	6072234

## HYDRAULIC FUNCTIONS

Hydraulic Functions	Truck Auxiliary Valves Required
2	2

## CONVERSION KIT

Model	Conversion	Catalog Order No.
22G/25G	Class II to III	6072573
22G/25G	Class III to II	6072574

Cascade Corporation • PO Box 20187 • Portland, OR 97294-0187 • USA • 800 CASCADE (227.2233) • Tel 503.669.6257 • Fax 800.693.3768 • Fax 503.669.6367  
 Cascade Canada Ltd. • 5570 Timberlea Blvd. • Mississauga, Ontario L4W 4M6 • Canada • 800.380.2272 • Tel 905.629.7777 • Fax 905.629.7785

Cascade is a registered trademark of Cascade Corporation.  
 © Cascade Corporation 2008. All rights reserved.

**cascade**  
 corporation  
 www.cascorp.com

Form 6071071 10M CG 1/08